

Write your name here

Surname

Other names

Pearson Edexcel
International
Advanced Level

Centre Number

--	--	--	--	--	--

Candidate Number

--	--	--	--	--	--

Physics

Advanced

Unit 6: Experimental Physics

Tuesday 14 November 2017 – Morning

Time: 1 hour 20 minutes

Paper Reference

WPH06/01

You must have:

Ruler

Total Marks

Instructions

- Use **black** ink or ball-point pen.
- **Fill in the boxes** at the top of this page with your name, centre number and candidate number.
- Answer **all** questions.
- Answer the questions in the spaces provided
– *there may be more space than you need.*

Information

- The total mark for this paper is 40.
- The marks for **each** question are shown in brackets
– *use this as a guide as to how much time to spend on each question.*
- The list of data, formulae and relationships is printed at the end of this booklet.
- Candidates may use a scientific calculator.

Advice

- Read each question carefully before you start to answer it.
- Try to answer every question.
- Check your answers if you have time at the end.

Turn over ►

P50797A

©2017 Pearson Education Ltd.

1/1/1/1/



Pearson

Answer ALL questions in the spaces provided.

1. A student plans to determine the density of a square, flat glass tile so that she can decide which type of glass it might be made from. The length and width of the tile are each about 20 mm.

She uses vernier calipers to measure the length and width of the tile and a micrometer screw gauge to measure the thickness of the tile.

- (a) (i) Estimate the percentage uncertainty in the measurement of length.

(1)

.....

.....

.....

- (ii) Explain one precaution she should take to ensure her measurements are as accurate as possible.

(2)

.....

.....

.....

.....

.....

DO NOT WRITE IN THIS AREA

DO NOT WRITE IN THIS AREA

DO NOT WRITE IN THIS AREA



(b) She records the following values for the tile.

Quantity	Measurement	Mean
Length / mm	23.4 23.6 23.4 23.2	23.4
Width / mm	23.0 23.1 23.2 23.1	23.1
Thickness / mm	7.93 7.96 7.97 7.94	

(i) Determine the mean value for the volume of the tile.

(2)

Mean volume =

(ii) Calculate the percentage uncertainty in the mean value for volume.

(3)

Percentage uncertainty =



(c) The student measures the mass of the glass tile as 10.03 g with a negligible uncertainty.

(i) Calculate the density of the glass.

(2)

.....

.....

.....

.....

Density of glass =

(ii) From a data book the student found the value for the density of crown glass to be 2500 kg m^{-3} .

Determine whether the tile could be made from crown glass.

(2)

.....

.....

.....

.....

.....

.....

.....

.....

(Total for Question 1 = 12 marks)



DO NOT WRITE IN THIS AREA

DO NOT WRITE IN THIS AREA

DO NOT WRITE IN THIS AREA

BLANK PAGE



2 A student investigates how the current through a thermistor varies with temperature between 0°C and 100°C .

(a) State why the resistance of the thermistor decreases as its temperature increases. (1)

.....

.....

(b) The student keeps the potential difference (p.d.) across the thermistor constant during the investigation.

(i) State why it is important to keep the p.d. constant. (1)

.....

.....

(ii) Draw a circuit diagram for the investigation. (3)



DO NOT WRITE IN THIS AREA

DO NOT WRITE IN THIS AREA

DO NOT WRITE IN THIS AREA

(c) The student needs to change and measure the temperature of the thermistor.

- (i) List the additional apparatus needed to change and measure the temperature of the thermistor in the range 0°C to 100°C . (2)

.....

.....

.....

.....

- (ii) Suggest one technique that would improve the accuracy of the temperature measurements. (1)

.....

.....

(Total for Question 2 = 8 marks)



3 A student carries out an experiment to determine the mass of a rock using the oscillations of the rock when suspended from a spring.

The formula for the time period T of vertical oscillations of a mass m suspended from a spring is

$$T = 2\pi \sqrt{\frac{m}{k}}$$

where k is a constant for the spring.

To calibrate the spring, the student suspends several known masses from the spring and measures T for each using a stopwatch.

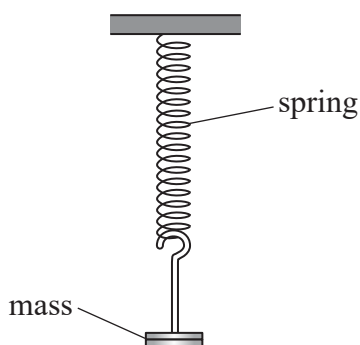

(a) State why the student should use a small amplitude of oscillation each time. (1)

.....

.....

.....

(b) Describe how he can ensure that the value for T is as accurate as possible. (2)

.....

.....

.....



DO NOT WRITE IN THIS AREA

DO NOT WRITE IN THIS AREA

DO NOT WRITE IN THIS AREA

(c) The student records several corresponding readings of m and T .

(i) Explain which graph he should plot to obtain a straight line.

(2)

.....

.....

.....

(ii) State how he should determine the mass of the rock.

(1)

.....

.....

(d) Suggest how using a position sensor and data logger, rather than a stopwatch, would improve the accuracy of the experiment.

(1)

.....

.....

(Total for Question 3 = 7 marks)



DO NOT WRITE IN THIS AREA

DO NOT WRITE IN THIS AREA

DO NOT WRITE IN THIS AREA

BLANK PAGE



DO NOT WRITE IN THIS AREA

DO NOT WRITE IN THIS AREA

DO NOT WRITE IN THIS AREA

- 4 A technician checked the capacitance C of a capacitor. She charged the capacitor then discharged it through a resistor of high resistance R . The circuit used is shown.

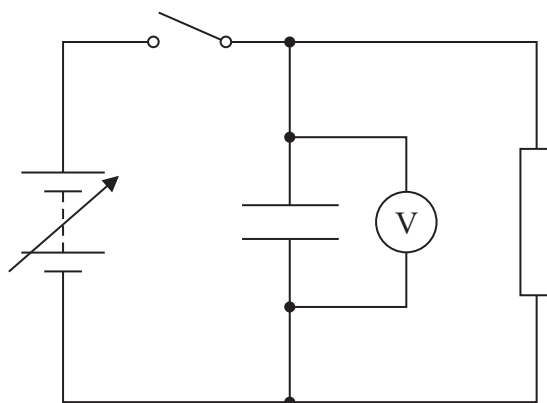

The potential difference (p.d.) V across the capacitor decreased as the capacitor discharged. The technician measured values of V at corresponding times t until the p.d. was half its initial value.

- (a) The technician repeated the measurements and calculated mean values of V .

State two additional ways she could have made her measurements as accurate as possible. (2)

.....

.....

.....

- (b) The relationship between V and t is given by

$$V = V_0 e^{-t/RC}$$

where V_0 is the p.d. at time $t = 0$.

Explain why a graph of $\ln V$ against t is a straight line. (2)

.....

.....

.....



(c) The following data were obtained.

t/s	Mean V/V	
0.00	6.00	
10.00	5.20	
20.00	4.56	
30.00	3.97	
40.00	3.40	
50.00	2.94	
60.00	2.59	

(i) Draw on the grid opposite a graph of $\ln V$ against t . Use the extra column in the table for your processed data.

(6)

(ii) Use your graph to determine a value for C .

(3)

$$R = 68 \text{ k}\Omega$$

$$C = \dots\dots\dots$$



DO NOT WRITE IN THIS AREA

DO NOT WRITE IN THIS AREA

DO NOT WRITE IN THIS AREA

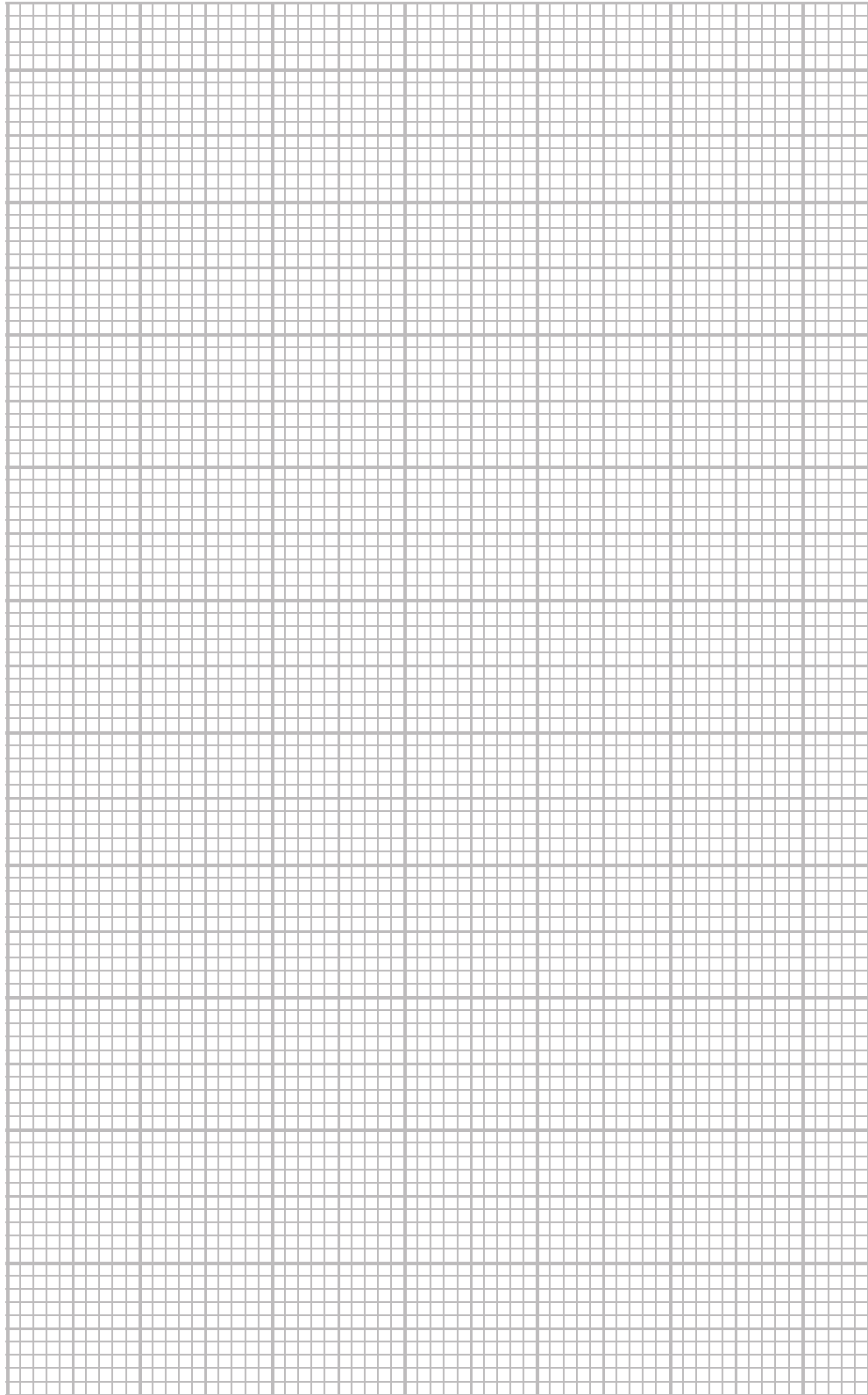

(Total for Question 4 = 13 marks)

TOTAL FOR PAPER = 40 MARKS



DO NOT WRITE IN THIS AREA

DO NOT WRITE IN THIS AREA

DO NOT WRITE IN THIS AREA

BLANK PAGE



DO NOT WRITE IN THIS AREA

DO NOT WRITE IN THIS AREA

DO NOT WRITE IN THIS AREA

BLANK PAGE



DO NOT WRITE IN THIS AREA

DO NOT WRITE IN THIS AREA

DO NOT WRITE IN THIS AREA

BLANK PAGE



List of data, formulae and relationships

Acceleration of free fall	$g = 9.81 \text{ m s}^{-2}$	(close to Earth's surface)
Boltzmann constant	$k = 1.38 \times 10^{-23} \text{ J K}^{-1}$	
Coulomb's law constant	$k = 1/4\pi\epsilon_0$ $= 8.99 \times 10^9 \text{ N m}^2 \text{ C}^{-2}$	
Electron charge	$e = -1.60 \times 10^{-19} \text{ C}$	
Electron mass	$m_e = 9.11 \times 10^{-31} \text{ kg}$	
Electronvolt	$1 \text{ eV} = 1.60 \times 10^{-19} \text{ J}$	
Gravitational constant	$G = 6.67 \times 10^{-11} \text{ N m}^2 \text{ kg}^{-2}$	
Gravitational field strength	$g = 9.81 \text{ N kg}^{-1}$	(close to Earth's surface)
Permittivity of free space	$\epsilon_0 = 8.85 \times 10^{-12} \text{ F m}^{-1}$	
Planck constant	$h = 6.63 \times 10^{-34} \text{ J s}$	
Proton mass	$m_p = 1.67 \times 10^{-27} \text{ kg}$	
Speed of light in a vacuum	$c = 3.00 \times 10^8 \text{ m s}^{-1}$	
Stefan-Boltzmann constant	$\sigma = 5.67 \times 10^{-8} \text{ W m}^{-2} \text{ K}^{-4}$	
Unified atomic mass unit	$u = 1.66 \times 10^{-27} \text{ kg}$	

Unit 1

Mechanics

Kinematic equations of motion	$v = u + at$ $s = ut + \frac{1}{2}at^2$ $v^2 = u^2 + 2as$
Forces	$\Sigma F = ma$ $g = F/m$ $W = mg$
Work and energy	$\Delta W = F\Delta s$ $E_k = \frac{1}{2}mv^2$ $\Delta E_{\text{grav}} = mg\Delta h$

Materials

Stokes' law	$F = 6\pi\eta rv$
Hooke's law	$F = k\Delta x$
Density	$\rho = m/V$
Pressure	$p = F/A$
Young modulus	$E = \sigma/\epsilon$ where Stress $\sigma = F/A$ Strain $\epsilon = \Delta x/x$
Elastic strain energy	$E_{\text{el}} = \frac{1}{2}F\Delta x$



Unit 2

Waves

Wave speed $v = f\lambda$

Refractive index ${}_1\mu_2 = \sin i / \sin r = v_1 / v_2$

Electricity

Potential difference $V = W/Q$

Resistance $R = V/I$

Electrical power, energy and efficiency

$$P = VI$$
$$P = I^2R$$
$$P = V^2/R$$
$$W = VI t$$

$$\% \text{ efficiency} = \frac{\text{useful energy output}}{\text{total energy input}} \times 100$$

$$\% \text{ efficiency} = \frac{\text{useful power output}}{\text{total power input}} \times 100$$

Resistivity $R = \rho l/A$

Current $I = \Delta Q / \Delta t$
 $I = nqvA$

Resistors in series $R = R_1 + R_2 + R_3$

Resistors in parallel $\frac{1}{R} = \frac{1}{R_1} + \frac{1}{R_2} + \frac{1}{R_3}$

Quantum physics

Photon model $E = hf$

Einstein's photoelectric equation $hf = \phi + \frac{1}{2}mv_{\max}^2$

DO NOT WRITE IN THIS AREA

DO NOT WRITE IN THIS AREA

DO NOT WRITE IN THIS AREA



Unit 4

Mechanics

Momentum	$p = mv$
Kinetic energy of a non-relativistic particle	$E_k = p^2/2m$
Motion in a circle	$v = \omega r$ $T = 2\pi/\omega$ $F = ma = mv^2/r$ $a = v^2/r$ $a = r\omega^2$

Fields

Coulomb's law	$F = kQ_1Q_2/r^2$ where $k = 1/4\pi\epsilon_0$
Electric field	$E = F/Q$ $E = kQ/r^2$ $E = V/d$
Capacitance	$C = Q/V$
Energy stored in capacitor	$W = \frac{1}{2}QV$
Capacitor discharge	$Q = Q_0 e^{-t/RC}$
In a magnetic field	$F = BIl \sin \theta$ $F = Bqv \sin \theta$ $r = p/BQ$
Faraday's and Lenz's laws	$\epsilon = -d(N\phi)/dt$

Particle physics

Mass-energy	$\Delta E = c^2 \Delta m$
de Broglie wavelength	$\lambda = h/p$

DO NOT WRITE IN THIS AREA

DO NOT WRITE IN THIS AREA

DO NOT WRITE IN THIS AREA



Unit 5*Energy and matter*

Heating $\Delta E = mc\Delta\theta$

Molecular kinetic theory $\frac{1}{2}m\langle c^2 \rangle = \frac{3}{2}kT$

Ideal gas equation $pV = NkT$

Nuclear Physics

Radioactive decay $dN/dt = -\lambda N$

$$\lambda = \ln 2/t_{1/2}$$

$$N = N_0 e^{-\lambda t}$$

Mechanics

Simple harmonic motion

$$a = -\omega^2 x$$

$$a = -A\omega^2 \cos \omega t$$

$$v = -A\omega \sin \omega t$$

$$x = A \cos \omega t$$

$$T = 1/f = 2\pi/\omega$$

Gravitational force $F = Gm_1 m_2 / r^2$

Observing the universe

Radiant energy flux $F = L/4\pi d^2$

Stefan-Boltzmann law

$$L = \sigma T^4 A$$

$$L = 4\pi r^2 \sigma T^4$$

Wien's law $\lambda_{\max} T = 2.898 \times 10^{-3} \text{ m K}$

Redshift of electromagnetic radiation $z = \Delta\lambda/\lambda \approx \Delta f/f \approx v/c$

Cosmological expansion $v = H_0 d$

